



FD73-135

Drilling Unit

■ Specification

Hydraulic Pressure	20~45kg/cm ²
Drilling Capacity	φ 25(mild steel)
Power	1.5-3.7kw, 4P, 220V/380V
Max. Revolution/Minute	3,000rpm
Weight	125kg
Stroke	Hydraulic-50~135mm Manual-50mm
Cylinder Diameter	φ 100
Cylinder Area	Forward 54.78cm ² , Backward 28.27cm ²
Thrust Force	1,640kg(30kg/cm ²)

■ Consumption Parts

Spindle Bearing	32008x1, 6008Zx1, 32007x1, 6007Zx1
Pulley Bearing	6013Zx2
O-Ring for Front Cover	DH-80x1, P-80x1, T601-80-90-6x1, G-105x1
O-Ring for Piston	P-90x2, G-65x1
O-Ring for Rear Cover	P55x1, T601-55-65-6x1, G-105x1

- This unit is mounted on a manual slide.
- Always use full hydraulic stroke.
- Stopper on spindle tail is not used.
- Suitable for higher RPM or high pressure.

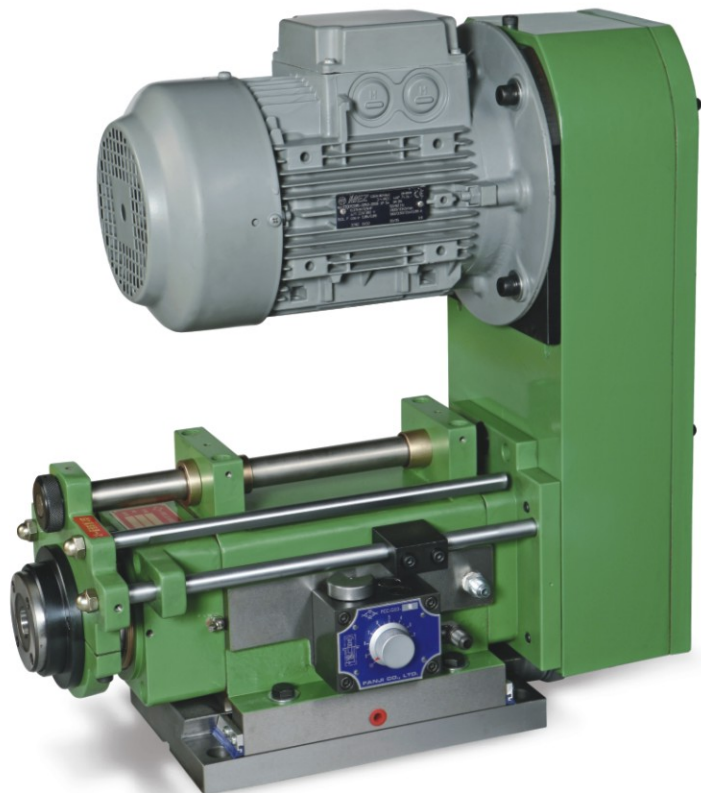



FD73-135

Drilling Unit

Dimensions

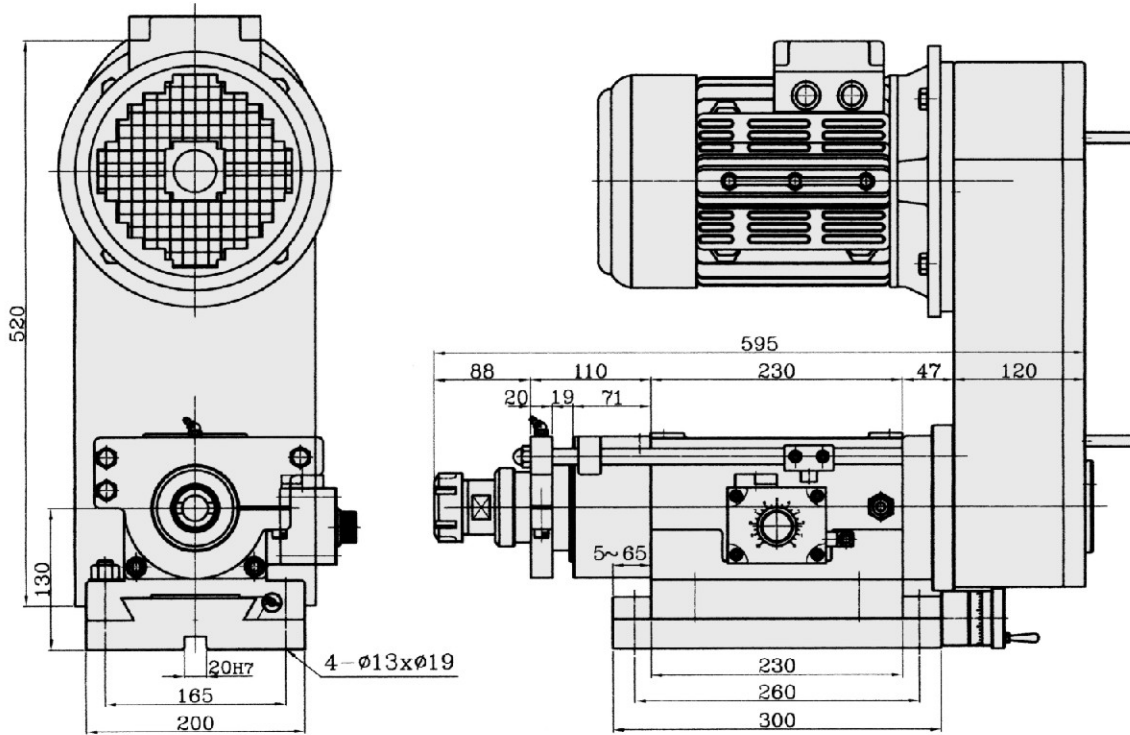

FD73M-135-MT3A Multi

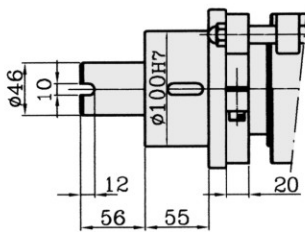

FD73-135-MT3A

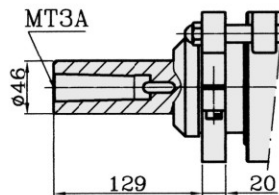

FD73-135-FB30

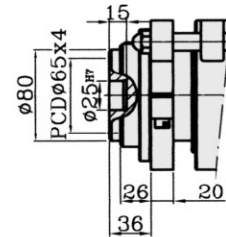

FD73-135-MT3B Multi

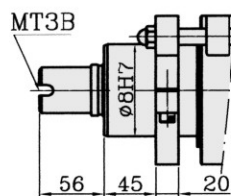

FD73-135-AS32

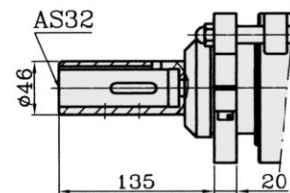

FD73-135-ER40

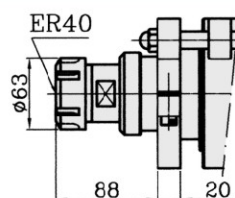

FD73-135-ER32

